

DIVERTING VALVES

# MOTORIZED ZONE VALVE SERIES ZRS230

The ESBE Series ZRS230 consists of motorized spring return 3-way zone valves available in DN 15-32, PN16 with internal thread connection.



ZRS230

### OPERATION

The ESBE Series ZRS230 is a range of 3-way diverting motorized zone valve with spring return actuator for use in heating and cooling system. The valve can easily be manually operated by the lever on the side of the actuator

The actuator is controlled by 2-point signal with spring return function and is recommended for diverting function, available for 230V AC, 50/60 Hz power supply.

Actuator is assembled on the valve with a screw attachment that allows to assembly/disassembly the actuator in a secure, simple and rapid way even when system is pressurized.

The product is intended to be used in closed circuits only.

### TECHNICAL DATA

#### Valve:

Pressure class: \_\_\_\_\_ PN 16  
 Media temperature: \_\_\_\_\_ max. +94°C  
 \_\_\_\_\_ min. +2°C  
 Media: \_\_\_\_\_ Water / Glycol mixtures, max. 50%.  
 (above 20% admixture, the pump data must be checked)  
 Working pressure: \_\_\_\_\_ 1.6 MPa (16 bar)  
 Max. differential pressure: \_\_\_\_\_ see diagram  
 Connections: \_\_\_\_\_ Internal thread (G), ISO 228/1 B

Material  
 Valve body: \_\_\_\_\_ Brass CW 614N  
 Ball: \_\_\_\_\_ NBR  
 O-rings: \_\_\_\_\_ EPDM

#### WIRING

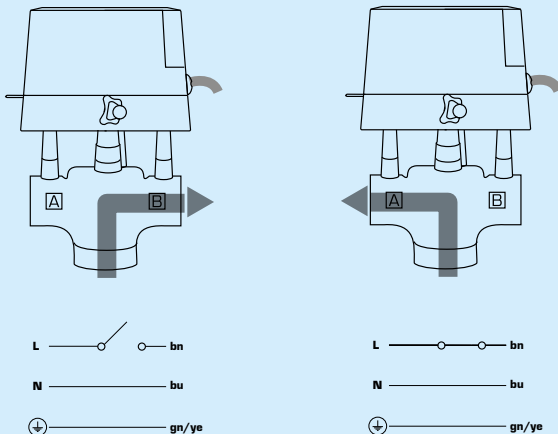

#### Actuator:

Ambient temperature: \_\_\_\_\_ max. +60°C  
 \_\_\_\_\_ min. 0°C  
 Enclosure rating: \_\_\_\_\_ IP44  
 Protection class: \_\_\_\_\_ I  
 Connection cable: \_\_\_\_\_ 1 meter  
 Power supply: \_\_\_\_\_ 230 V AC, 50/60 Hz  
 Control signal: \_\_\_\_\_ 2-point (2-wire spring return)  
 Power consumption: \_\_\_\_\_ 6 VA  
 Running time, opening: \_\_\_\_\_ 15 seconds  
 closing: \_\_\_\_\_ 5 seconds

CE LVD 2014/35/EU  
 EMC 2014/30/EU  
 RoHS 2011/65/EU  
 PED 2014/68/EU, article 4.3

# MOTORIZED ZONE VALVE SERIES ZRS230

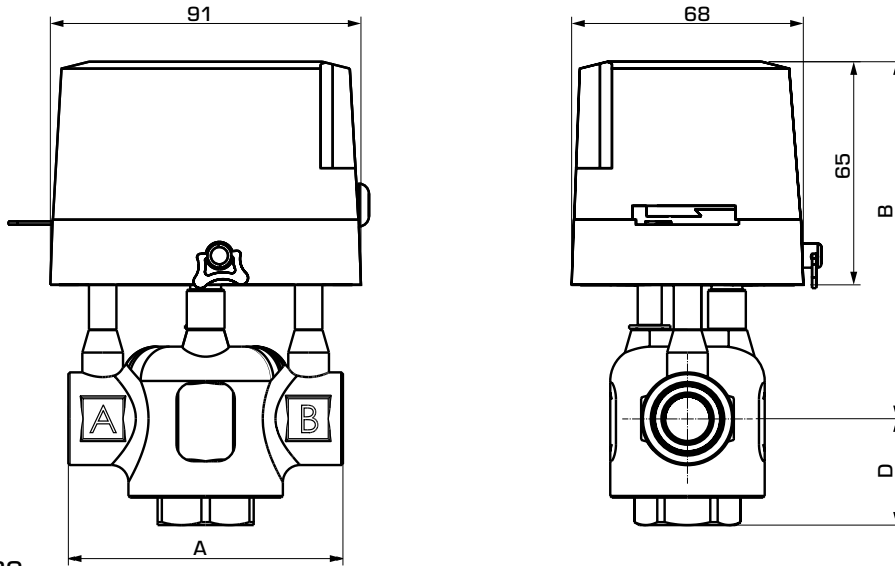

ZRS230

## SERIES ZRS234, INTERNAL THREAD

Art. No.	Reference	DN	Kvs*	Max. differential pressure [kPa]	Connection	A	B	D	Weight [kg]	Note
43123100	ZRS234	15	3.2	150	G 1/2"	80	103	29	1.02	
43123200		20	4.6		G 3/4"	89		32	1.07	
43123300		25	5.7	100	G 1"	93	37	1.16		
43123400		32	8.4		G 1 1/4"	105	45	1.58		

\* Kvs-value in diverting mode measured as m<sup>3</sup>/h at a pressure drop of 1 bar.

## INSTALLATION EXAMPLE

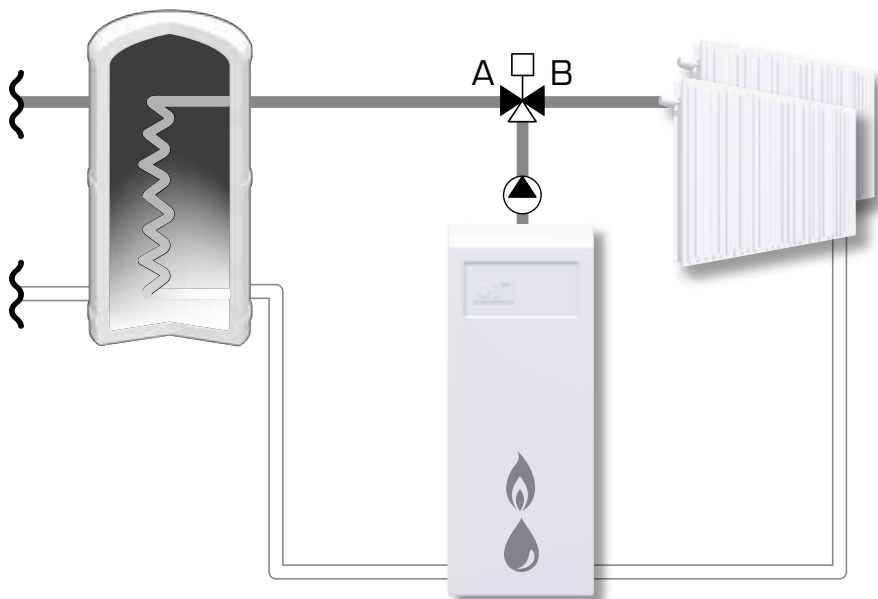

# MOTORIZED ZONE VALVE SERIES ZRS230

## PRESSURE DROP DIAGRAM

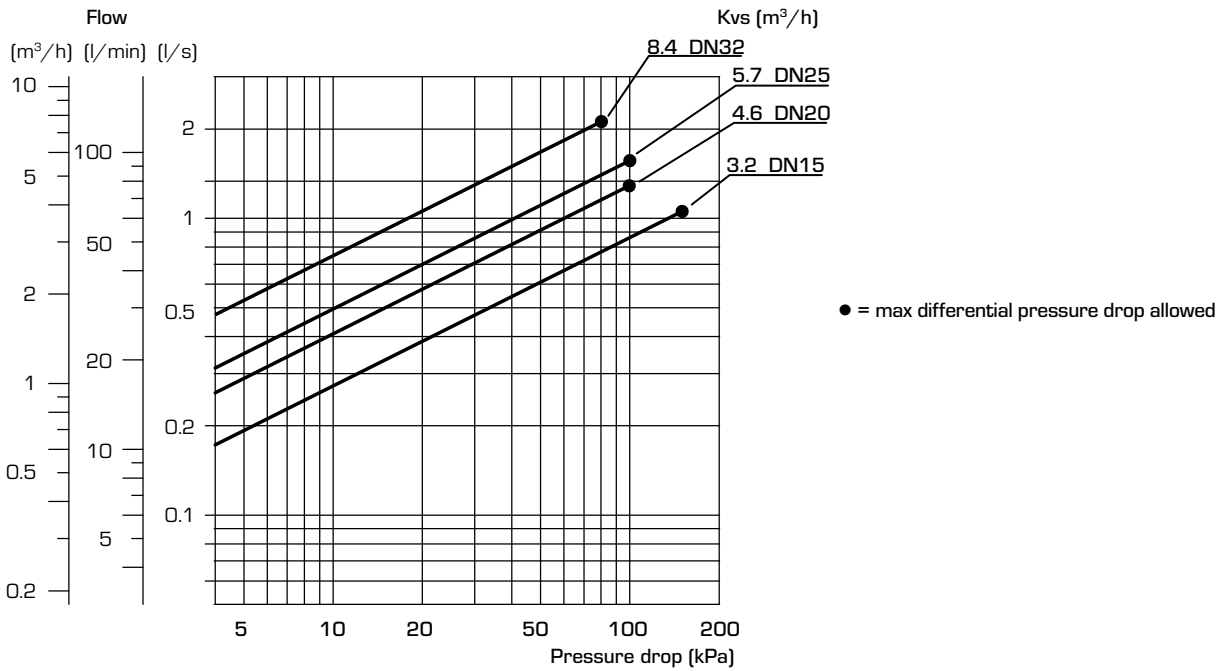

The product is intended to be used in closed circuits only.